

MultiWRAPPER™ Packaging System

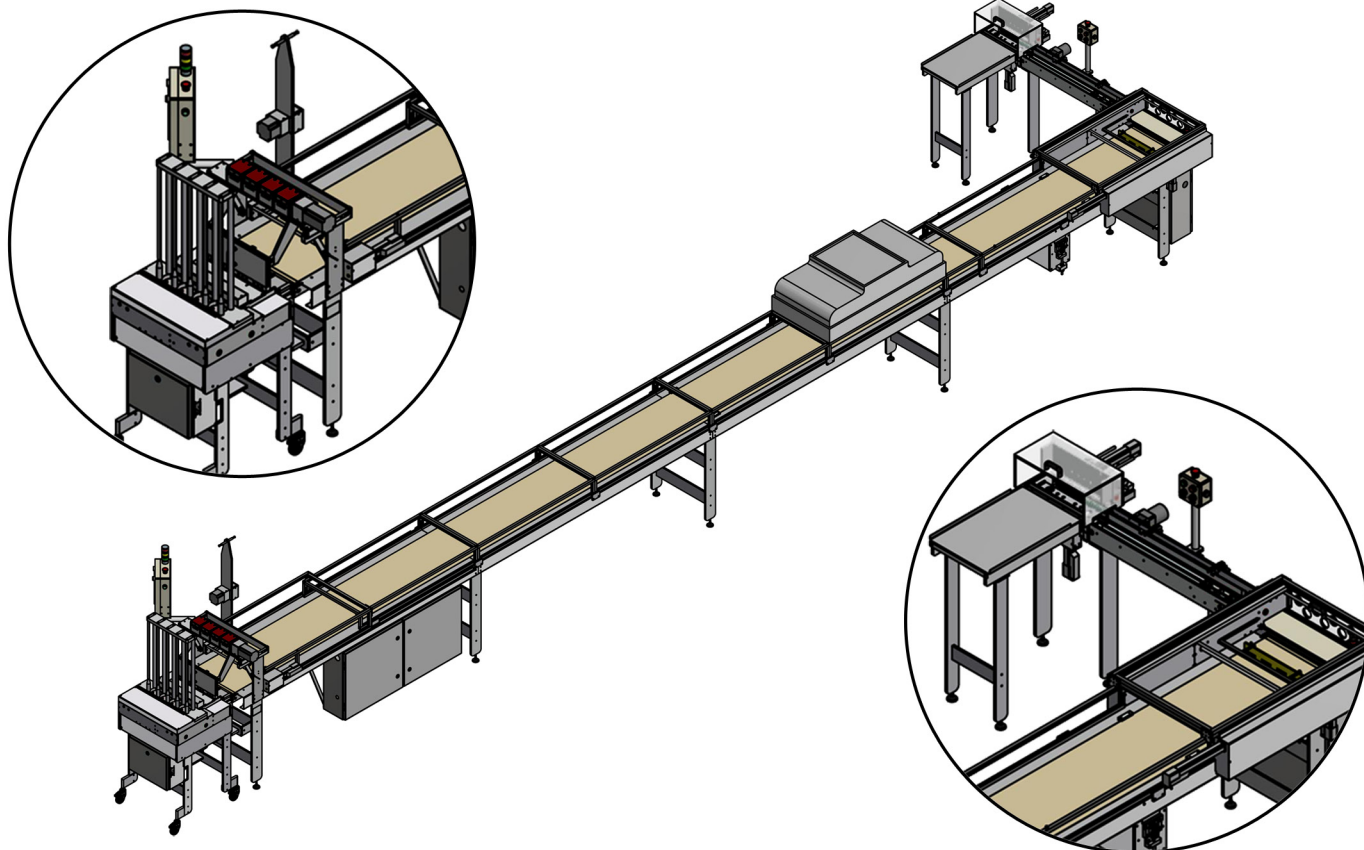

FEATURES

- Interchangeable Head Unit for quick changeover to accommodate dishes 55-150mm wide
- EasyLOAD™ Magazine
- Flexible Conveyor Length
- Right/Left Operator Panel and Enclosure Locations
- Precision Peristaltic Pumps: No drips, no bubbles
- Convenient Additive System
- Positive Meniscus Generation
- Multicavity Orientation
- Sterile Cooling Tunnel with HEPA Protection
- Bottom Print Station with trigger
- LED Backlit Inspection Station
- Right/Left Output Direction
- Automatic Stacking
- Convenient Buffer Table
- CE Certified

ADDITIONAL OPTIONS

- Additional Head Units for Increased Flexibility
- Bulk Loading
- Nozzle Heating Unit
- Rotating Pump Group with Auto Purge
- Individual Pump Control
- Large Screen HMI
- Reduced Lane Operation Capabilities
- HEPA Monitoring and Control
- Rejection System
- Custom Output and Wrap Conveyor Options
- Rotary Edge or Custom Print Station
- Convenient Buffer Table
- Auto Refeed Buffer System
- IQ/OQ Documentation

ONLINE

Engineering inc.

MultiWRAPPER™ Packaging System

Specifications

- Pumps: Proprietary ONLINE peristaltic twin-track
- Operator Interface: Touchscreen monitor and Push button panels
- Controls: Siemens S7 series microprocessor, Watch-dog timers on all transfers
Optical proximity, laser, and fiber optic sensors
Vacuum switch Solid-state
Control Voltage 24VDC
- Services: 220 VAC, 50/60 Hz, 15 amps, 3.3kW
Compressed air, clean non-lubricated, 80 psig
- Construction: Stainless steel, aluminum, high-density polyethylene plastic, polycarbonate
- Conveyor: Stainless steel beds on aluminum frames with spliced endless belt of 1.5mm polyester base with urethane facing
- Main Belt Drive: VFD/VFI

System Functions

- Stacks of dishes are manually loaded by operator
- Dishes are unstacked and uncovered
- Multicavity plates are oriented
- Dishes are filled and covers replaced
- Covers are partially removed to enhance evaporation
- Dishes travel down the drying tunnel
- Covers are replaced and dishes are transferred to the cross conveyor
- Dishes cross the print and inspection stations
- Dishes are stacked to predetermined stack count
- Stacks of dishes are transferred to Outfeed (buffer table, buffer refeed system, or wrap-feed conveyor)

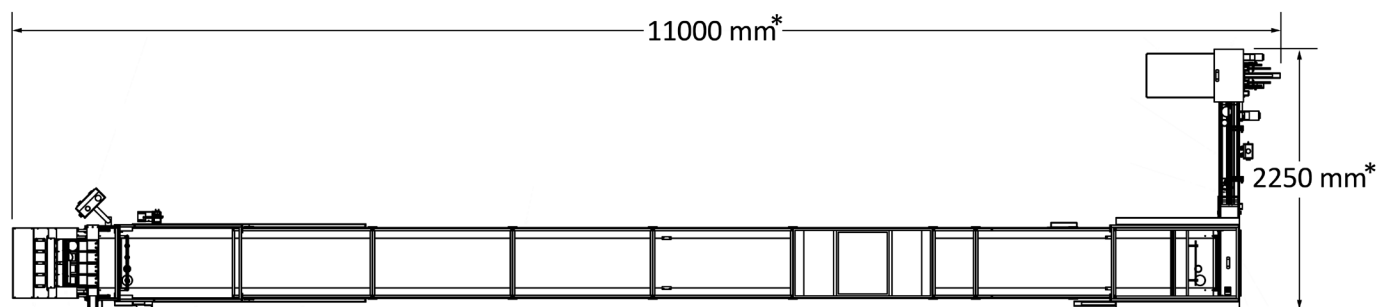

Working Height: 900 mm;

* Overall length and width variable based upon configuration options.

Model	# of Lanes/Pumps	Conveyor Width	Nominal Throughput
964	4	17"/432mm	4,000 units per hour
965	5	21"/533mm	6,000 units per hour
968	8	33"/838mm	9,000 units per hour
916	10	41"/1041mm	12,000 units per hour

Throughput rates are for standard system options with the following parameters: 90mm configuration with 18mL fill volume and 3.5m dry time.

ONLINE Engineering inc. is a global supplier of petri dish filling machines, test tube filling machines, bottle filling machines and other prepared media production equipment. We understand that a quick return-on-investment is important. Our goal is to provide the quality of equipment and service that significantly contribute to your success.

400 North Cedar St. • Manistique, MI 49854 • USA • Phone: 906-341-0090 • www.online-engineering.com